



STUDIO-KANS™

By METROPHONES®

METRONOME HEADPHONE SYSTEM

Bluetooth™

USER MANUAL

SAFETY INFORMATION

Important Safety Instructions

1. Read these instructions and keep for future reference.
2. Follow all instructions and maintenance guide.
3. Do not use this product near water.
4. Always use attachments/accessories specified by the manufacturer.

CAUTION

- Hearing experts advise against continuous extended play. **DO NOT** use these or any headphones at a high volume for an extended period of time. If you experience a ringing in your ears, reduce volume or discontinue use.
- Not intended for use as hearing protection.
- **DO NOT** drop, sit on or allow the headphones to be immersed in water.

STUDIO-KANS' BLUETOOTH™ HEADPHONES

PACKAGE INCLUDES:

- Studio-Kans' Bluetooth™ Headphones
- USB Charging Cable and Power Adapter

INTRODUCTION/ABOUT

Thank You for choosing Studio-Kans' Bluetooth™ Headphones. Studio-Kans' Bluetooth™ Headphones were designed by musicians for musicians. Our technology allows the musician to hear more of their instruments dynamic nuances and other details that are usually lost with standard headphones.

Features

1. Bluetooth™ 4.0 enabled.
2. Noise reduction up to 29dB.
3. Excellent low frequency fidelity.
4. Enhances audio with HD Live Mix (Amplifies frequencies that are lost in a passive system).
5. Auto switching (Wired audio to Bluetooth™).
6. Energy sufficient (Auto off after 5 minutes when not paired to a device).
7. 35 meters/115 feet range (Ideal case with no obstruction or interference).
Note: Range varies from each device. Each device will have its own range specifications. Please see your devices operation manual for more information.
8. Rechargeable battery (40 hours). Works with standard USB battery charging.
9. True dynamic listening designed for musicians, "Hear Every Instrument Nuance".
10. Total comfort gel filled cushions (Reduces ear fatigue from long term use).
11. Adjustable, soft padded headband for the perfect fit.

Technical Specification

- **Battery:** Rechargeable Li-ion Battery (40 hours)
- **Rated Input Power:** 100mW
- **Maximum Input Power:** 200mW
- **Sensitivity:** 103 dB ± 3 dB at 1mW/1kHz
- **Frequency Response:** 10 -25000 Hz
- **Bluetooth™:** 4.0 Controls

KNOWING YOUR STUDIO-KANS' BLUETOOTH HEADPHONE

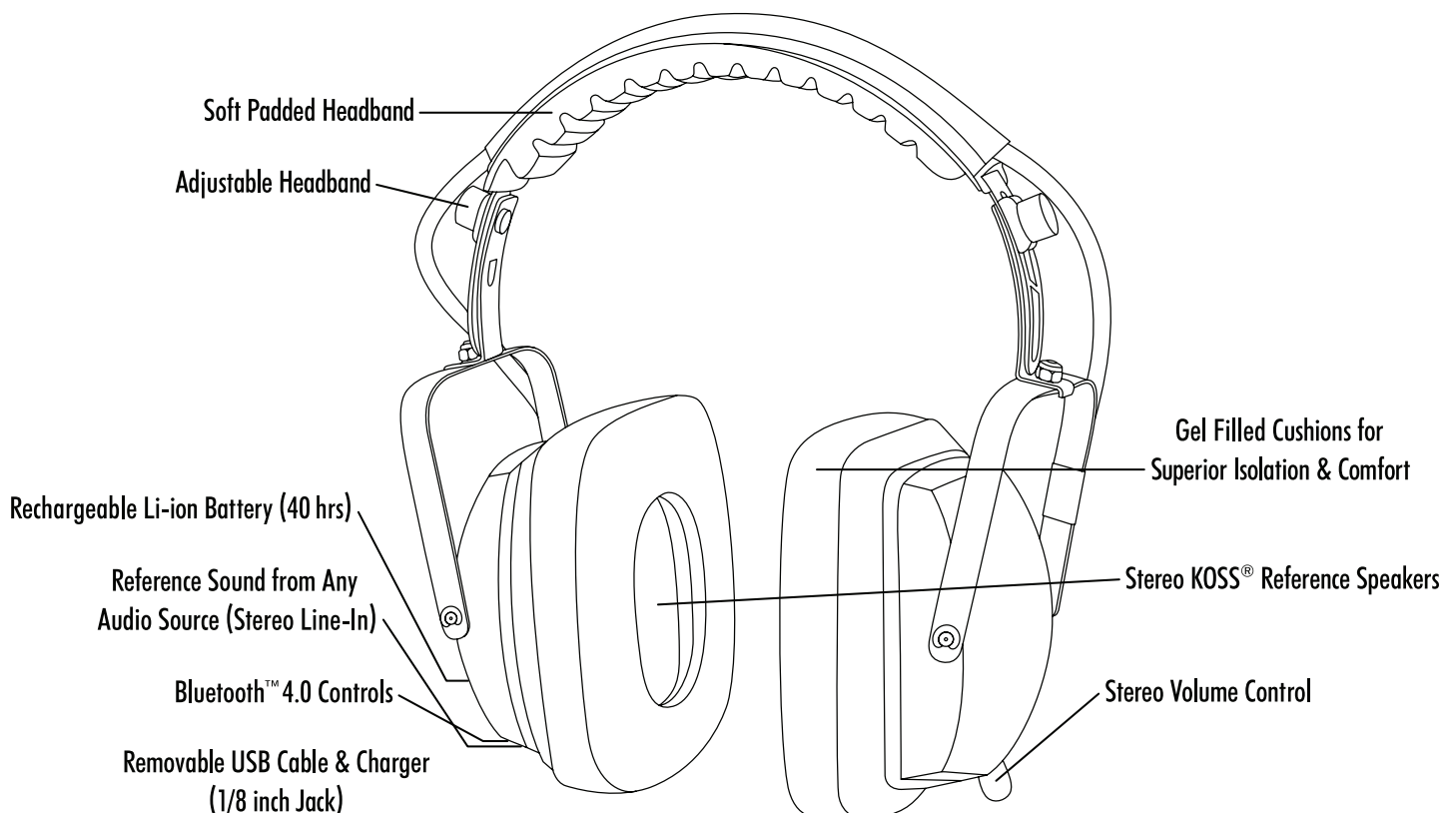

CHARGING THE BATTERY

We recommend you fully charge the battery overnight before first time use.

1. **Battery Charge:** Allow up to 5 hours for a full charge.
2. **Battery Life:** 40 hours based on average use of features.
3. To charge battery, plug the 1/8" jack USB cable into the headphones and the USB end to your computer or a USB wall charger.
4. A **red light** will turn on indicating that the battery is being charged.
5. Once the battery is completely charged, a **blue light** will turn on steady.

Note: Using the metronome and Bluetooth™ at the same time will decrease the battery life by 1/8.

CONTINUED

USING STUDIO-KANS' BLUETOOTH™ HEADPHONES

Studio-Kans' Bluetooth™ Headphones are considered active headphones, not passive. Audio will not work unless Bluetooth™ is powered on. Once you turn on the Bluetooth™ for a wired input, the audio amp will continue to work. At this point you can turn off the Bluetooth™ to save power.

Bluetooth™ Operation

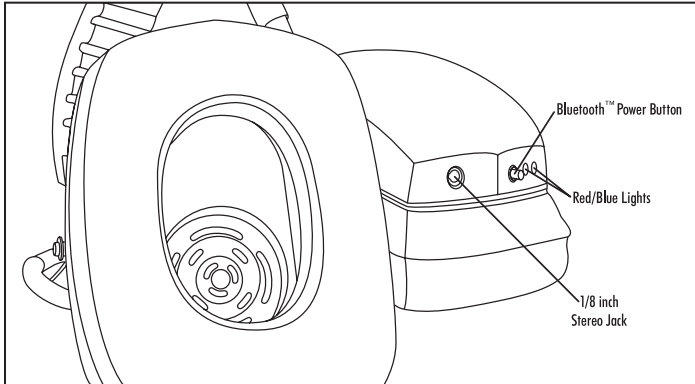

Figure 2

1. **Power On** – Hold the **Bluetooth™ power button** (Figure 2) for 1 second. A **red light** should appear as well as a voice command stating **“power on”**.
2. **First time pairing** with Bluetooth™ devices (computer, smartphone or tablet).
 - Hold the Bluetooth™ power button for about 5 seconds, the **blue light and red light** (Figure 2) will flash in alteration while trying to find your device.
 - Go to your device's settings in the Bluetooth™ section and make sure the Bluetooth™ is turned on in your device and select **“MP-Kasha Amps”**. The **blue light** will blink twice to notify it is connected with your device, as well as a voice command stating **“your device is connected”**.*
 - After the initial pairing, the device and headphones should connect automatically once you turn the Bluetooth™ on.

* Note: Refer to the Owner's Guide that came with your device for any problems locating the headphone connection on your device.
3. **Controlling your device** – You can control your music from your music program interface OR you can **pause** and **play** by pressing the **Bluetooth™ power button** on your headphones for 1 second.
4. **Disconnecting** – Hold the **Bluetooth™ power button** for 5 seconds and your headphones will power off and disconnect.
5. **Power off** – Hold the **Bluetooth™ power button** for 5 seconds and the **blue light and red light** will turn off as well as a voice command stating **“your headset is disconnected”**.
6. The headphones and Bluetooth™ will auto power off in 5 minutes if no device is connected.

Recognizing the Voice and Tones Indicators

Voice Indicators

- a. **On:** “Power on”
- b. **Off:** “Power off”
- c. **Pairing with device:** “Pairing”
- d. **Connected:** “Your headset is connected”
- e. **Disconnected:** “Your headset is disconnected”
- f. **Battery Low:** “Battery low”

External Audio Input

- External jack will not work unless Bluetooth™ is **powered on**. To use an external input source, connect the **audio cable** (not included) into the **1/8 inch Stereo Jack** (Figure 2). External audio is now enabled.
Note: Bluetooth™ will shut off in 5 minutes when not connected, but the external audio input will continue to function.
- When external audio source is connected, listen for these tones:
 - a. **Power On:** 4 notes rising
 - b. **Power Off:** 4 notes falling
 - c. **Low Battery:** Low tone
 - d. **Pairing:** 2 notes rising
- If the device is paired via Bluetooth™ while using external audio input:
 - Bluetooth™ play will override external audio play.
 - Pausing Bluetooth™ play will switch to external audio within 5 seconds.

Volume Control

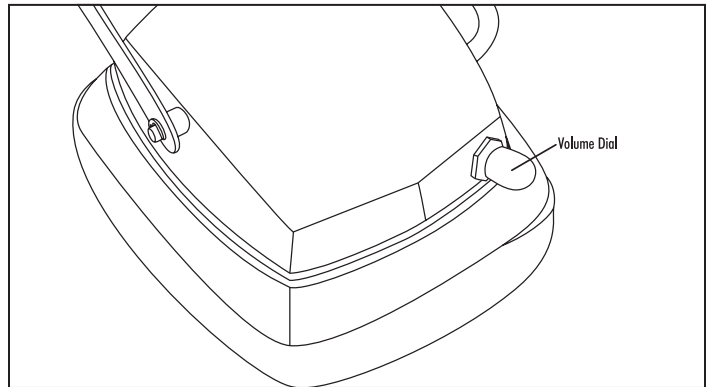

Figure 3

Adjust volume by turning the **Volume Dial** (Figure 3).

MAINTENANCE

Battery Care

Always keep battery charged.

Cleaning the Headphones

Do not use harsh chemicals or alcohol to clean your Studio-Kans' Bluetooth™ Headphones. Only use a damp cloth with mild soap and water.

Replacing the Parts

Replacement parts and accessories, such as the Gel Filled Cushions (GFC), can be ordered through Big Bang Distribution. Visit www.bigbangdist.com for more info.

FOR BETTER CARE, ASK YOUR DEALER ABOUT A PADDED METROPHONES CARRYING CASE (MPB).

ONE YEAR LIMITED WARRANTY

Big Bang Distribution (B.B.D.) warrants, to the original purchaser, that the Studio-Kans' Headphones shall be free from defects in material and workmanship, under normal use, for one year of the original purchase (battery, cable, cushions not included).

This warranty will not apply if the product has been misused, abused, altered, serviced by anyone other than those authorized to do so by Big Bang Distribution, or used in any commercial or institutional setting. In the event of a defect, in accordance with the terms of this warranty, B.B.D. agrees, at its option, to repair or replace the product without charge to the consumer for parts and labor. B.B.D. reserves the right to alter or improve the product at any time without prior notice. Repair or replacement as provided under this warranty is the exclusive remedy of the consumer. Big Bang Distribution shall not be liable for any incidental or consequential damages for breach of any express or implied, warranty on this product. Except to the extent prohibited by applicable law, any implied warranty of merchantability or fitness for a particular purpose on this product is limited in duration to the duration of this warranty.

Some states do not allow the exclusions or limitation of incidental or consequential damages or allow limitations on how long an implied warranty lasts, so the above limitations or exclusions may not apply to you. This warranty gives you specific legal rights and you may have other rights, which vary from state to state.

Proof of purchase in the form of a bill of sale must be presented with the product within the warranty period in order to obtain service.

TO OBTAIN SERVICE: Return the product postage prepaid with proof of purchase to the address below.

BIG BANG DISTRIBUTION
9420 Reseda Blvd., PMB 350, Northridge, CA. 91324
www.BigBangDist.com

Scan the QR Code to Learn More

